



HIGH WING MOLD CO. LIMITED

海威模具有限公司





- HIGH WING MOLD CO. LIMITED, based in Shenzhen since its foundation in 2004, has specialized in the development and manufacturing of an extensive array of spool products. Our product line encompasses NPS spools, automotive wire reels, fiber optic and cable spools, in-house turnover reels for wire and cable factories, generic wire and cable packaging reels, as well as large, heavy-duty spools.
- The company boasts a highly skilled technical team, state-of-the-art production and testing facilities, and is fully certified under the ISO 9001:2008 quality management system. Besides our broad selection of standard spools available for order, we also offer bespoke manufacturing services for custom spool designs.
- At High Wing Mold, we pride ourselves on being a comprehensive provider of services spanning from mold creation to product development and manufacturing. We are confident in our ability to deliver products of exceptional quality at minimized costs. We eagerly anticipate the opportunity to collaborate with you, aiming to forge a prosperous future and build a lasting friendship.
- 海威模具有限公司位于深圳，公司2004年建立以来，专业开发生产线盘产品，有NPS线盘，汽车线盘，光纤线盘，光缆线盘，线缆工厂内部周转盘，普通电线电缆包装线盘，大型重型线盘。公司现拥有优秀的技术团队和先进的生产设备及检测设备，完全通过ISO9001:2008质量管理体系认证，现除了有多款线盘可订购，同时可以制造特殊线盘。
- 海威模具作为一个从模具到产品开发制造加工工艺一条龙服务的公司，相信可以为您提供品质优异，成本最低化的产品，真诚期待与您携手合作，共创未来，能成为您更好的朋友！

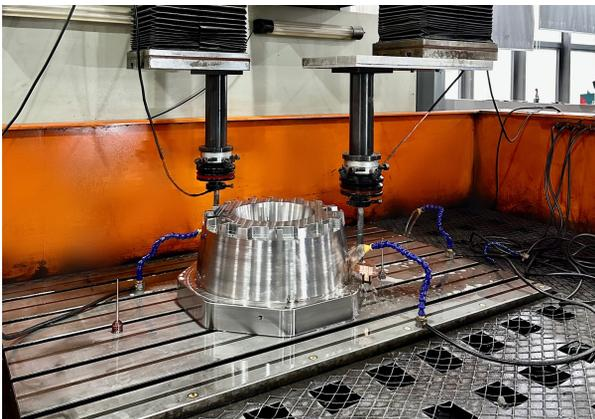

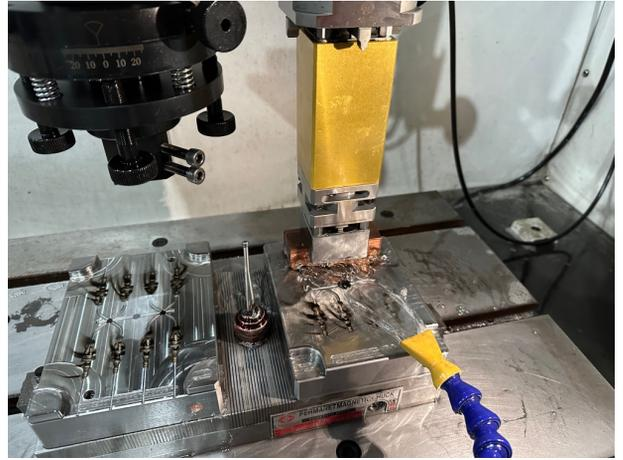

Internal transfer Drum

- Designed for internal transfer of during the wire processing.
- ABS injection molding
- Good balance, high strength, impact resistant, anti-acid corrosion
- Durable, can be reused.

机用周转线盘

- 采用进口ABS注塑成型
- 平衡性能好，强度高，耐冲击，耐酸碱腐蚀
- 可重复使用



| dimension | mm |
|------------------|-----------|
| flange diameter | 630 |
| barrel diameter | 315 |
| inner distance | 315 |
| outer distance | 365 |
| center hole | 56 |
| flange thickness | 25 |
| material | ABS |
| weight | 15kg |
| structure | assembled |

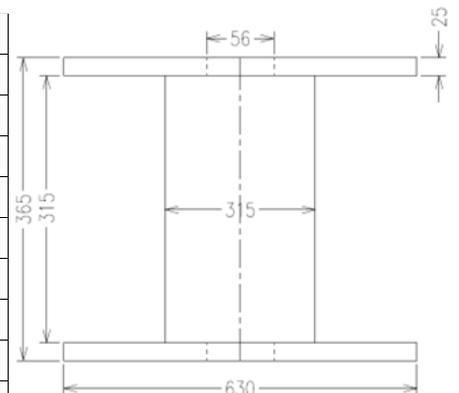

NPS series-Automotive Wire Reels

- Designed for delivering and transporting interior wires for automobiles.
- Made from ABS plastic through injection molding.
- High strength, good toughness, and convenient usage.

NPS系列 汽车线材类线盘

- 用于汽车内部线缆交货，周转的线盘
- 产品采用ABS注塑成型，强度高，韧性好，使用方便



| | | |
|------------------|-------------------|--|
| dimension | mm | |
| flange diameter | 400 | |
| barrel diameter | 260 | |
| inner distance | 100 | |
| outer distance | 162 | |
| center hole | 80 | |
| flange thickness | 25 | |
| material | ABS | |
| weight | 2100 | |
| structure | 2 parts assembled | |



| | | |
|------------------|-------------------|--|
| dimension | mm | |
| flange diameter | 400 | |
| barrel diameter | 260 | |
| inner distance | 150 | |
| outer distance | 212 | |
| center hole | 80 | |
| flange thickness | 25 | |
| material | ABS | |
| weight | 2200 | |
| structure | 2 parts assembled | |



| | | |
|------------------|-------------------|--|
| dimension | mm | |
| flange diameter | 400 | |
| barrel diameter | 260 | |
| inner distance | 250 | |
| outer distance | 312 | |
| center hole | 80 | |
| flange thickness | 25 | |
| material | ABS | |
| weight | 2400 | |
| structure | 2 parts assembled | |



| | | |
|------------------|-------------------|--|
| dimension | mm | |
| flange diameter | 400 | |
| barrel diameter | 260 | |
| inner distance | 400 | |
| outer distance | 462 | |
| center hole | 80 | |
| flange thickness | 25 | |
| material | ABS | |
| weight | 2600 | |
| structure | 2 parts assembled | |

PC series-Metal Wire Reels

- Designed for the turnover and delivery of copper wire, tinned wire, alloy wire, and other metal wires.
- The reel primarily comes in two structures: integral and composite. It is manufactured using materials such as ABS, PA, PS, PP, etc.
- Featuring excellent balance and high strength, these reels are recyclable for repeated use.

PC系列 金属线材类线盘

- 适用于铜线、镀锡线、合金线等金属线材的周转、交货线盘。
- 产品主要分为一体式和组合式两种结构
- 采用ABS, PA, PS, PP等原材料生产。平衡性好、强度高，可回收重复使用。

| Model | D1 Flange OD | D2 Barrel OD | L1 Inner Width | L2 Overall Width | D4 Center Hole | S Flange Thickness | Structure | Material |
|--------|--------------|--------------|----------------|------------------|----------------|--------------------|------------|----------|
| RT-200 | 203 | 130 | 194 | 223 | 32.5 | 14.5 | integrated | ABS |
| RG-170 | 171 | 79 | 192 | 221 | 32.5 | 14.5 | integrated | ABS |
| RK-200 | 203 | 70 | 194 | 221 | 32.5 | 13.5 | integrated | ABS |
| NB-140 | 140 | 70 | 194 | 213 | 16.5 | 9.5 | integrated | ABS |



RT-200



RK-200



RG-170



NB-140

3D Printing Filament Spool 750g/1000g

- Designed for 3D Printing Filament/Resin delivery or storage.
- Made from ABS material, offering excellent toughness. Optional materials include PC, PS, and others.
- Featuring an integral structure, which ensures stability and high strength.

3D打印耗材类线盘 750g/1000g

- 200型750g 3D打印耗材线盘
- 该线盘用于3D打印耗材包装交货。
- 产品采用ABS原料注塑成型，韧性好，可选PC, PS等材质
- 整体结构，稳定性好，强度高。



750g

| dimension | mm | |
|------------------|----------|--|
| flange diameter | 200 | |
| barrel diameter | 105 | |
| inner distance | 47 | |
| outer distance | 53 | |
| center hole | 52 | |
| flange thickness | 3.5 | |
| material | PC/ABS | |
| weight | 207g | |
| structure | one part | |



1000g

| dimension | mm | |
|------------------|----------|--|
| flange diameter | 200 | |
| barrel diameter | 105 | |
| inner distance | 70 | |
| outer distance | 77 | |
| center hole | 52 | |
| flange thickness | 3.5 | |
| material | PC/ABS | |
| weight | 233g | |
| structure | one part | |

Fiber Optic Spool

- Designed for packaging and delivery of fiber optics.
- Material: ABS, which ensures toughness.
- Structure: Integrated, which provides stability and high strength.
- The spool body is equipped with sponge to protect the fiber optics from damage.

光纤线盘

- 该线盘用于光纤包装交货。
- 产品采用ABS原料注塑成型，韧性好。
- 整体结构，稳定性好，强度高，
- 筒体有海绵保护光纤不受损伤



Fiber 25km

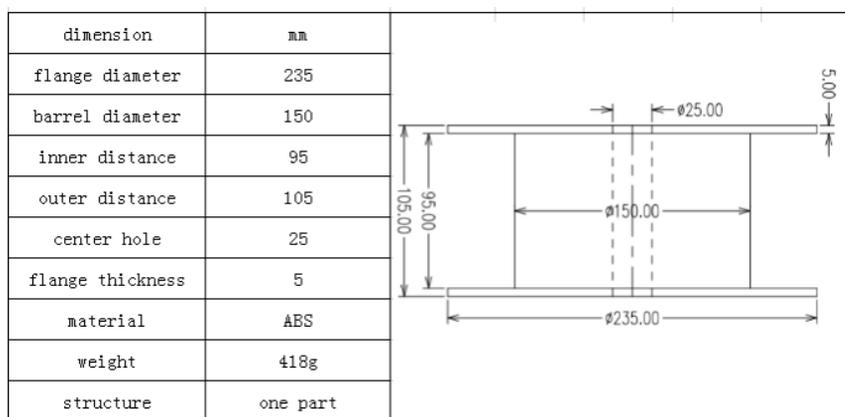

Fiber 50km

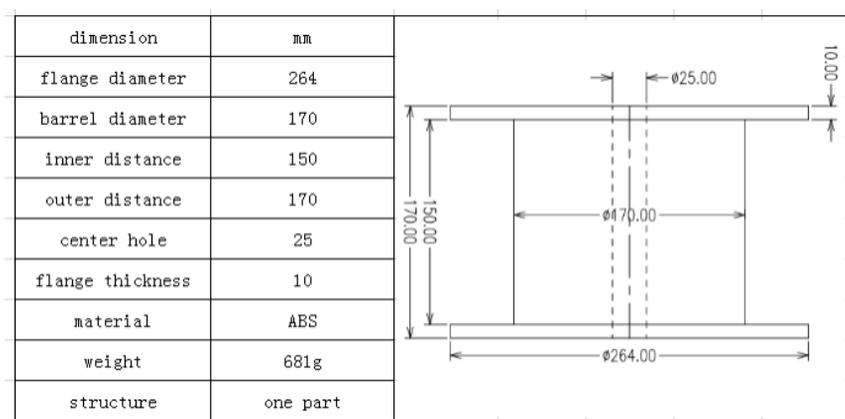

Coil Pack

- Designed for finished coil packs
- Structure: Assembled
- Materials: ABS, PS, PP, etc.
- Can be reused, recycled. Good balance, high strength, durable.



| dimension | mm |
|------------------|-----------|
| flange diameter | 265 |
| barrel diameter | 90 |
| inner distance | 180 |
| outer distance | 196 |
| center hole | 42 |
| flange thickness | 8 |
| material | ABS |
| weight | 249 g |
| structure | assembled |

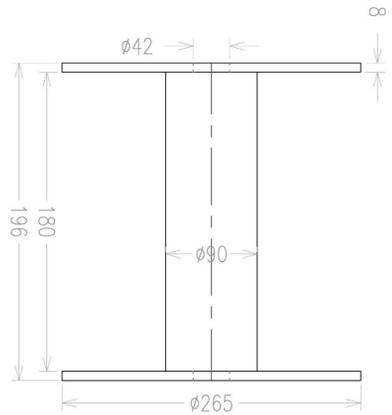

线圈盘

- 用于成品线圈
- 设计用于金属线的交付和储存。
- 两种结构：整体和组合式。
- 材料：ABS、PS、PP等。
- 可重复使用、可回收。平衡性好、强度高、耐用

DIN series- Metal Wire Reels

- Designed for delivery and storage of metal wires.
- Two structures: Integrated & Assembled
- Materials: ABS, PS, PP, etc.
- Can be reused, recycled. Good balance, high strength, durable.

DIN系列：金属丝线盘

- 设计用于金属线的交付和储存。
- 两种结构：整体和组合式。
- 材料：ABS、PS、PP等。
- 可重复使用、可回收。平衡性好、强度高、耐用。



| dimension | mm | |
|------------------|-----------|--|
| flange diameter | 300 | |
| barrel diameter | 206 | |
| inner distance | 91 | |
| outer distance | 102 | |
| center hole | 52 | |
| flange thickness | 5.5 | |
| material | ABS/PS/PP | |
| weight | 608g | |
| structure | one part | |

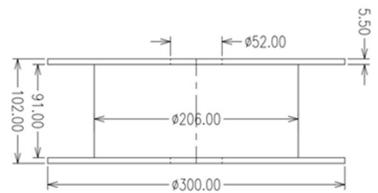

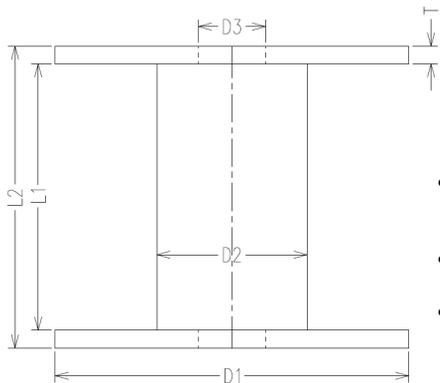

PL-Light Series

- The PL series cable spools are suitable for packaging and transportation of cables, fiber optics, and other types of wires.
- The product can be manufactured using different materials
- such as PP, ABS, PS, etc., according to customer requirements.

PL-轻型系列

- PL系列线盘适用于电线、电缆、光纤等线材的包装及运输
- 产品根据客户需求，可采用PP、ABS、PS等不同材料生产



6.5 ''*4.5''

6.5 ''*6.5''

6.5 ''*8''

12 ''

14''

| Model | D1 Flange OD | D2 Barrel OD | L1 Inner Width | L2 Overall Width | D4 Center Hole | S Flange Thickness | Material |
|----------------|--------------------|--------------------|----------------------|------------------------|----------------------|--------------------------|----------|
| PL-14'' | 14'' | 4'' | 11.5'' | 12.7'' | 1.5'' | 0.6'' | PP/PE |
| PL-12'' | 12'' | 4'' | 11.5'' | 12.7'' | 1.5'' | 0.6'' | PP/PE |
| PL-12''-5'' | 12'' | 4'' | 5'' | 5.5'' | 1.8'' | 0.6'' | PP/PE |
| PL-6.5''-8'' | 6.5'' | 2'' | 8'' | 8.4'' | 0.8'' | 0.2'' | PP/PE |
| PL-6.5''-6.5'' | 6.5'' | 2'' | 6.5'' | 6.9'' | 0.8'' | 0.2'' | PP/PE |
| PL-6.5''-4.5'' | 6.5'' | 2'' | 4.5'' | 4.9'' | 0.8'' | 0.2'' | PP/PE |

PL-Heavy Series

- Designed for heavy duty wires.
- The PL series wire spools are suitable for packaging and transportation of wires, cables, fiber optics, and other types of wires.
- The product can be manufactured using different materials
- such as PP, ABS, PS, etc., according to customer requirements.

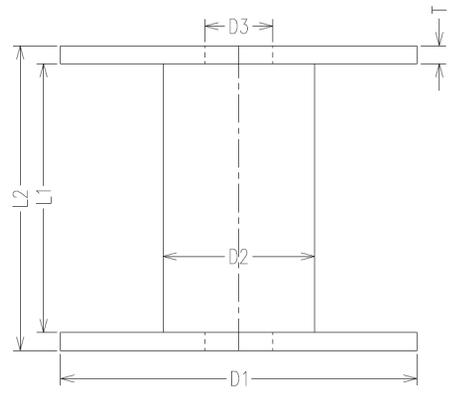

PL-重型系列

- PL系列线盘适用于电线、电缆、光纤等线材的包装及运输
- 产品根据客户需求，可采用PP、ABS、PS等不同材料生产



400*150*300



500*140*290



600*250*400

| model | D1 (mm) | D2 | D3 | T | L1 | L2 | material | weight (g) |
|-------------|---------|-----|----|------|-----|-----|----------|------------|
| 600*250*400 | 600 | 250 | 80 | 35 | 400 | 470 | PP | 7000 |
| 500*140*290 | 500 | 140 | 38 | 15 | 290 | 320 | PP | 5000 |
| 400*150*190 | 400 | 150 | 57 | 22.5 | 200 | 245 | PP | 1920 |
| 400*150*240 | 400 | 150 | 57 | 22.5 | 250 | 295 | PP | 1965 |
| 400*150*290 | 400 | 150 | 57 | 22.5 | 300 | 345 | PP | 2065 |
| 400*150*340 | 400 | 150 | 57 | 22.5 | 350 | 395 | PP | 2120 |
| 400*150*405 | 400 | 150 | 57 | 22.5 | 415 | 460 | PP | 2240 |
| 300*100*150 | 300 | 100 | 38 | 15 | 150 | 180 | PP | 800 |
| 300*100*200 | 300 | 100 | 38 | 15 | 200 | 230 | PP | 920 |
| 300*130*130 | 300 | 130 | 30 | 15 | 130 | 160 | PP | 830 |
| 300*130*190 | 300 | 130 | 30 | 15 | 190 | 220 | PP | 890 |
| 300*150*260 | 300 | 150 | 70 | 15 | 260 | 290 | PS | 600 |

800mm-1200mm Heavy Duty Drums

- Used for delivering and transporting various types of wires, cables, and optical fiber.
- Made from modified PP plastic through injection molding, offering high strength and excellent toughness.
- Featuring a split structure, easy to assemble, disassemble, and convenient for recycling and reuse.
- Available in multiple spacing sizes: 840, 660, 600, 560, 480, 400.

800mm-1200mm 大型塑料电缆盘

- 该线盘用于电线,电缆,光缆等各种线缆的交货、周转线盘。
- 产品采用改性PP塑料注塑成型,强度高,韧性好。
- 分体结构:方便组装,拆卸,方便回收再使用。
- 盘间距有多种尺寸: 840,660,600,560,480,400



| dimension | mm |
|------------------|-----------|
| flange diameter | 1200 |
| barrel diameter | 630 |
| inner distance | 646 |
| outer distance | 800 |
| center hole | 82 |
| flange thickness | 77 |
| material | PP |
| weight | 70 KG |
| structure | assembled |

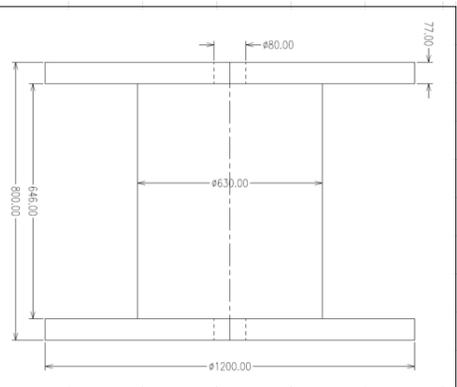

| dimension | mm |
|------------------|----------|
| flange diameter | 1000 |
| barrel diameter | 500 |
| inner distance | 660 |
| outer distance | 780 |
| center hole | 86 |
| flange thickness | 60 |
| material | PP |
| weight | 27804g |
| structure | assemble |

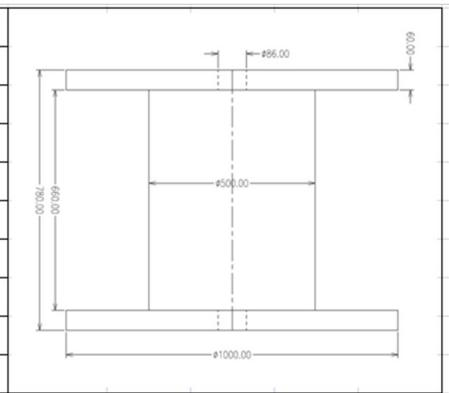

| dimension | mm |
|------------------|----------|
| flange diameter | 800 |
| barrel diameter | 400 |
| inner distance | 400 |
| outer distance | 520 |
| center hole | 86 |
| flange thickness | 60 |
| material | PP |
| weight | 14860g |
| structure | assemble |

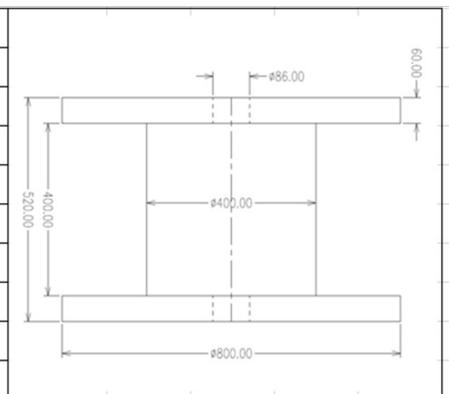



Factory Location: Building 3, 1-3 Floor, Hengxin Zihui Technology Park, Shuikou Street, Huicheng District, Huizhou City, Guangdong, China

Contact: Robert Gao

Phone: +8613923770845

Email: robertgao@highwingmold.com

Official website: <http://www.highwingmold.com>

工厂地址：惠州市惠城区水口街道办事处联合村恒信智慧科技园3号厂房1-3楼

联系人：高先生

联系电话：13923770845

公司网址：<http://www.highwingmold.com>